



Diocesan Advisory Committee (DAC)

CHURCHYARD REGULATIONS FOURTH EDITION 2020

Rules relating to
burial, interment of cremated remains
and the placing of memorial/gravestones in churchyards
in the Diocese of Gloucester

Contents

Regulation

1	Introduction.....	2
2	Burial	3
3	Who is involved?	4
4	Memorials/gravestones/plaques.....	5
5	Burial of cremated remains	9
6	Vaults and above-ground funerary edifices.....	11
7	Interment within or below the church.....	12
8	Flowers	12
9	Reservation of grave spaces.....	12
10	Exhumation	13
11	Burial depths.....	13
12	Commonwealth War Graves Commission.....	14
13	American-style caskets.....	14
14	Trees	14
15	Closure of churchyards.....	15
16	Legal reservations.....	16
17	Further advice	16
18	Useful contacts.....	17
19	Relevant Publications and Useful Addresses	18
Schedule 1	Parish priest's permission.....	19
Schedule 2	Memorial/gravestone application form	25
Schedule 3	Grave space reservation form	31

I Introduction

I.1 These churchyard regulations (the **Regulations**) aim to help all those in the Diocese of Gloucester who wish for themselves, or for a friend or relative, to be buried in a churchyard in this diocese. They are designed to assist:

- those who may wish to leave instructions to their relatives as to their own wishes as to burial, cremation and memorials/gravestones;
- those who have been bereaved, so they know what is permissible in a particular graveyard; and
- funeral directors and others to explain these Regulations to their clients, and to comply themselves with them.

These Regulations aim to strike a balance between the needs of grieving families and the wider interests of church members and the general public. Compliance with the provisions of these Regulations is accordingly important in helping to avoid unnecessary upset and costs in the future.

I.2 As churchyards are consecrated, they fall under the jurisdiction of the Consistory Court, and these Regulations are therefore binding upon all. These Regulations are binding not only on those who are seeking to use the churchyard for coffin burials, the interment of cremated remains (ashes) and the erection of memorials/gravestones but also on the clergy, funeral directors, parochial church councils (PCCs) and all others who have an interest in the use and enjoyment of churchyards in the diocese. It should be noted that where these Regulations are silent on a particular matter it does not mean that such a matter is permitted. Matters are only authorised if they are expressly permitted by these Regulations or otherwise approved by the Chancellor. If there is any doubt or disagreement on the meaning of any Regulation and what is or is not permitted, advice should be sought from the relevant Archdeacon or the Diocesan Registry in the first instance.

I.3 Throughout the country, every diocese has churchyard regulations. Churchyards are important parts of rural and urban life. They are places of peace and tranquillity, reflection and memory, places that mark lives past, and on some occasions backdrops for important celebrations such as baptisms, weddings and national celebrations. Churchyards are important, not only to those whose loved ones might be buried there, but also in establishing the setting of the church. The Diocese of Gloucester has a large number of beautiful churchyards and it is therefore very important to ensure that they are maintained in good order as befits a final resting place for the departed and so as to preserve their historical, archaeological, architectural and ecological qualities. These regulations seek to enhance and protect all that is loved within our churchyards and to protect them from harm.

I.4 A churchyard is consecrated to its purpose in the name of God, Father, Son and Holy Spirit, and with any burials in it, or works to it, this special status must be recognised. Those responsible for maintaining the churchyard must therefore ensure that whatever is done is in accordance with Christian principles. All are encouraged to think about their funeral arrangements in good time so that potentially difficult decisions such as whether a family member wishes to be buried or cremated and in either case, where they would wish to be buried or interred, are not left to the next of kin to decide at what can be a very difficult and emotional time.

I.5 It is important for all to remember that a memorial (a headstone) is intended to be a public statement about a person that will survive the test of time. Something that will resonate not just with the relatives and friends but speaks to that person's place within the community, and which future generations will read and understand something of that person.

I.6 These Regulations apply in every churchyard in the Diocese. Archdeacons, parish priests and PCCs

must therefore:

- 1.6.1 give them as much local publicity as possible;
- 1.6.2 **keep a copy of them on permanent display in either the church porch or on its parish website if it has one and make clear in the church porch where a copy of the Regulations can be obtained;**
- 1.6.3 supply copies to monumental masons who undertake work in the churchyard; and
- 1.6.4 bring them to the attention of relatives who are seeking the burial of a relative at the earliest opportunity.

1.7 The day to day care of a churchyard is the legal responsibility of a PCC. This maintenance is not paid for by a Parish Council nor a Local Authority (unless it has been closed by Order in Council - see Regulation 13), so the PCC of a parish church is entitled to adopt its own regulations supplementing these Regulations provided that they do not purport to authorise any matter that is expressly not authorised by these Regulations. Such regulations may be more restrictive than these Regulations provided that they are reasonable, taking into account the particular characteristics and qualities of that churchyard, needs for maintenance or safety issues etc. Such additional regulations must be approved by way of a formal PCC resolution. In considering any application for a faculty, the Chancellor will give due consideration to any such local regulations but shall not be bound by them.

2 **Burial**

2.1 ***Can anyone be buried in a particular churchyard of their choice?***

2.1.1 No. Some people have a legal right to be buried in a particular churchyard, for example anyone

- who was a parishioner in that particular parish at the time of their death;
- who died in that particular parish; or
- whose name was, at the date of death, entered in the electoral roll maintained on behalf of that particular church (this is not the same as the civil parish's electoral roll).

2.1.2 The above rights apply in respect of both coffin burials and the interment of cremated remains, provided that the particular a churchyard is open and has not been closed by Order in Council, whether or not such a person was baptised or was a member of the worshipping community or was even a member of the Church of England.

2.2 ***What about someone who may have had past connections with a particular church but not at the time of death?***

2.2.1 *Existing graves*

If there is adequate depth in an existing grave, the incumbent may give permission for another deceased member of the same family to be buried in that grave. Similarly, cremated remains can be interred in a grave already containing the body/bodies of the relatives of the deceased.

HOWEVER, THIS CAN BE CONTROVERSIAL, AND SUCH A PROPOSAL MUST BE ACCEPTABLE TO THE CLOSE RELATIVES OF THE FAMILY/FAMILIES CONCERNED.

An incumbent in these circumstances will ask for written assurances from all

relevant family members (including divorced family members and their relatives) that they are agreeable to the proposed new burial / cremated remains being placed in the existing grave. Care should also be taken to ensure that any additional inscriptions to existing memorials/gravestones are also agreed by the legal owners of the existing memorials/gravestones.

2.2.2 *A new grave*

An incumbent may, in consultation with his/her PCC consider on its merits any application for a new grave for someone with past connections to a particular church. The need to conserve the limited number of grave spaces in some churchyards for the use of current parishioners means that such permission may be granted sparingly and only to those with strong family connections and/or particular service to that church

2.3 ***Can a particular spot be chosen in a churchyard for a grave?***

2.3.1 No. As a general rule no one can insist on being buried in a particular place. In any churchyard, the PCC can agree a general plan which takes account of the physical constraints of the land available for single/double grave depths. Other factors such as flooding risk may have to be considered as well. The parish priest in consultation with the PCC will identify the place where a new grave may be dug.

2.3.2 A parish priest may agree that a person may be buried in a particular location in a churchyard. However, that agreement is voided if the parish priest leaves the parish before the person concerned has died.

2.3.3 The only certainty over choosing a location for a grave is where a person has obtained a faculty from the Chancellor for a particular grave space to be **reserved** for the burial of their body (see Regulation 9). Only the Chancellor has the power to reserve a particular grave space before someone has died.

2.3.4 It is vitally important that parish priests and PCCs ensure that every church has an up to date plan of burials within its churchyard so that grave reservations can be marked properly for consideration by others in the future. A PCC seeking to conform to best practice should be able to inform the parish priest, at the Annual Parochial Church Meeting that the churchyard plan is up to date and that two copies exist, one of which is in the church safe.

3 **Who is involved?**

3.1 The key individuals and organisations who may be involved in granting permission relating to various aspects of the churchyard are:

3.1.1 The **Chancellor**, who is the Ecclesiastical Judge in the Diocese and is ultimately responsible for decisions affecting churchyards. It is the Chancellor who decides upon applications for memorials/gravestones which fall outside the scope of the limited powers devolved to parish priests (as set out in these Regulations). The Chancellor also has the power to remove an inappropriate memorial/gravestone that has been unlawfully introduced into the churchyard.

3.1.2 The **Archdeacons** can be contacted for advice in relation to churchyards, particularly where, for example, a parish priest is uncertain whether to give permission for the erection of a memorial/gravestone or change to an inscription on an existing memorial/gravestone. The Archdeacons can also apply to the Chancellor for the removal of an inappropriate memorial/gravestone.

3.1.3 The **parish priest** may be known as the 'Incumbent', 'Vicar', 'Rector' or 'Priest-in-Charge'. He or she is able to take routine decisions affecting the churchyard, including the approval of

memorials/gravestones within certain limits set out in these Regulations.

3.1.4 When there is no parish priest, for example during a vacancy in the benefice, decisions about burials and memorials/gravestones will be taken by the **Area Dean** who will be another parish priest in the area.

3.1.5 Each parish has a **Parochial Church Council** or PCC which is responsible for maintaining the churchyard and may need to give its approval to certain decisions.

3.2 A list of useful contacts can be found at Regulation 18. If in any doubt, relatives should ask for advice before taking any steps which might prove expensive if not approved.

4 Memorials/gravestones/plaques

4.1 *General principles*

4.1.1 A graveyard need not be absolutely uniform, but memorials/gravestones must conform to agreed standards, to ensure they are acceptable to the wide variety of people who come to mourn their relatives. Each churchyard is special to those who live close to it and to those who have relatives buried within it. It would be wrong for one grieving family to impose their tastes and views about memorials/gravestones on all others connected to the churchyard. Most importantly, all those who have been buried in the churchyard will have been laid to rest with a degree of respect and finality, in land that has been consecrated i.e. set apart solely for sacred purposes for all time. Memorials should not detract from the fundamental nature of a churchyard as a Christian burial place. For this reason, there are general principles which have to be applied.

4.1.2 Local Authority cemeteries may have wider parameters of individual choice for gravestones, but in the Diocese of Gloucester many of our churches are of national importance and their surrounding churchyards deserve special care.

4.1.3 There is no right in law given to anyone to have a memorial/gravestone erected in a churchyard, even if they are buried there, nor to have any particular inscription on such a memorial/gravestone. These matters require express permission. See also Regulation 4.1.7 below.

4.1.4 From a legal point of view, the introduction of memorials/gravestones into churchyards is authorised by the Chancellor. However, in practice the Chancellor has delegated certain powers to parish priests, who are able to give consent to the introduction of certain memorials/gravestones provided that they comply strictly with these Regulations. If the proposed memorial/gravestone is outside these Regulations, then those intending to erect it must apply by petition to the Chancellor for permission to do so.

4.1.5 Those intending to erect a memorial/gravestone should not enter into any agreement with a monumental mason for its supply until the necessary permission for its introduction into the churchyard has been granted either in writing by the parish priest or by way of a "faculty" granted by the Chancellor. A faculty application is a request for permission made to the Chancellor of the Diocese. The application is made by way of a "petition" and must be paid for by the applicant. Applications for a coffin burial memorial should not be made until a minimum of six months have elapsed since the interment although relatives are encouraged to wait one year. This is to enable the ground to settle and ensure that applications are not made in haste, but instead following a period of reflection. Ground subsidence following burial can lead to memorials becoming unstable thereby posing a potential safety hazard so the longer the ground is left to settle before a memorial is erected the better. Applications for memorials for cremated remains can be made three months after interment.

4.1.6 Certain types of memorial/gravestone are not permitted, either because they are felt to be

inappropriate in appearance, out of keeping in a Christian burial place, or because they are likely to be difficult to maintain (or a combination of these reasons).

- 4.1.7 Each churchyard should be harmonious in appearance and should form a worthy setting for the church in its midst. The design and choice of material for a memorial/gravestone should therefore take account of the established character of the churchyard and all new stones should be compatible with, and appropriate to, their surroundings. See also Regulation 4.4.5.
- 4.1.8 A churchyard is not a private place in which anything is acceptable but rather a place where many people have a shared interest in its appearance. The Chancellor therefore has the power to require the removal of any inappropriate memorial/gravestone, or an inappropriate feature on a memorial/gravestone, placed in a churchyard without proper permission. An inscription on a memorial/gravestone is a public statement about the person who is being commemorated, which may last after the bereaved have themselves died. Such an inscription should be accurate as to names, dates of birth and death and any quotation on the stone should be consistent with Christian principles. It is therefore essential that any person wishing to erect a memorial/gravestone should obtain proper permission to do so before a memorial/gravestone is placed in a churchyard. Although in the normal way graves will be left undisturbed, no guarantee can be given that this will forever be the case. There are occasions when proposed works such as an extension to a church building or a road widening scheme may result in the Chancellor granting a faculty for exhumation and reinterment elsewhere.

4.2 **Responsibility for memorials/gravestones**

- 4.2.1 Memorials/gravestones are the property of the person or persons who paid for them and after those persons themselves have died, the heir or heirs of the person commemorated on them. However, the ground in which someone is buried at all times remains the property of the incumbent. Any questions regarding the identity of the legal owner of a memorial/gravestone should be raised with the parish priest in the first instance.
- 4.2.2 It is the responsibility of the owner of a memorial/gravestone to maintain it. Care should be taken to choose memorials/gravestones, which are adequately and safely secured into the ground conforming to the National Association of Memorial Masons guidelines. Owners may wish to insure their memorial/gravestone as it will not be covered by the PCC's insurance policy. Neither the PCC nor the Diocese will accept any liability for any damage caused to memorials/gravestones resulting from lack of maintenance, vandalism, weathering or acts of God.
- 4.2.3 **Contractors, including funeral directors and monumental masons, are reminded that before undertaking any work in a churchyard they MUST verify that permission has been granted either in writing by the parish priest or by faculty granted by the Chancellor.** If work is carried out without the appropriate permission, those responsible (including the contractor) may be required to bear the expenses of rectification and contractors may be debarred from further work within the Diocese.
- 4.2.4 **If circumstances arise when memorials/gravestones have to be removed, the PCC must apply to the Chancellor for permission to do so by way of a faculty petition. The Archdeacon also has the right to petition the Chancellor for the removal of memorials/gravestones that have been introduced into a churchyard in breach of these Regulations. In any such case the Chancellor has the power to make an order for costs against any person whom the Chancellor finds**

responsible for having acted in breach of these Regulations.

4.3 Memorials/gravestones which may be authorised by the parish priest

- 4.3.1 The parish priest is authorised by the Chancellor to approve memorials/gravestones and suitable inscriptions without a faculty provided that such memorials/gravestones or inscriptions comply with Schedule I of these Regulations.
- 4.3.2 In relation to the burial of any body, the following memorials/gravestones may be authorised by the parish priest under delegated powers from the Chancellor and accordingly do not require a faculty:
- (a) Simple upright grave markers (provided that they comply with the provisions of Schedule I).
 - (b) Sloping 'open-book' memorials/gravestones (provided that they comply with the provisions of Schedule I).
 - (c) Wooden crosses (provided that they comply with the provisions of Schedule I).
 - (d) Additional suitable inscriptions on existing memorials/gravestones.
- 4.3.3 In relation to the interment of any cremated remains, the following memorials may be authorised by the parish priest under delegated powers from the Chancellor and accordingly do not require a faculty:
- (a) Temporary wooden crosses (provided that they comply with the provisions of Schedule I).
 - (b) Additional inscriptions on existing memorials/gravestones.
 - (c) Simple flush horizontal markers, in respect of the interment of cremated remains within an existing grave or elsewhere in a specifically designated area of the churchyard authorised by faculty (provided that such markers comply with the provisions of Schedule I). No memorial may be authorised which is not sufficiently flush with the ground so as to enable a lawnmower to pass over it at the normal setting for cutting grass.
 - (d) Burial markers, in respect of the interment of cremated remains within a designated Garden of Remembrance provided that they comply with the provisions of Schedule I and accord with local regulations as defined by the terms of the faculty under which the Garden of Remembrance within the churchyard was established.
- 4.3.4 Upright headstones, sloping tablets, open books, small metal plaques and any other form of memorial are not permitted for marking graves where cremated remains have been interred even if such markers already exist and were permitted in the past.
- 4.3.5 The size, shape, lettering, decoration and material applicable to a particular memorial/gravestone must also comply with the provisions of Schedule I.
- 4.3.6 In order to facilitate the maintenance of a churchyard, kerb stones, gravel or chippings may not be authorised by the parish priest and are very unlikely to be approved by faculty even in churchyards where graves with such features are already present.
- 4.3.7 **Any memorial/gravestone, which it is proposed should have features not covered**

by these Regulations, will require a faculty.

4.4 Application procedure for the authorisation of a memorial/gravestone by the parish priest

- 4.4.1 The parish priest's written consent in the prescribed form must be obtained before a memorial/gravestone is commissioned and placed in the churchyard. Applications should be made on the appropriate application form to the parish priest (see Schedule 2). The application form is also available from parish priests, the Archdeacons, the DAC or the Diocesan Registrar. It may be downloaded from the Diocese's website (www.gloucester.anglican.org/parish-life/church-buildings-and-churchyards/faculties).
- 4.4.2 Applicants will be required to confirm in writing on the application form that all family members who may reasonably be regarded as having an interest in the memorial/gravestone have been consulted and that there are no objections to the proposed memorial/gravestone.
- 4.4.3 In accordance with Regulation 4.1.4, an application may not be submitted until a minimum of six months has elapsed between the burial of the person to be commemorated and the application for permission for the memorial/gravestone. This is so as to allow time for the ground to settle before erecting a memorial/gravestone and to enable friends and relatives a proper period of time to reflect on the type of memorial/gravestone that is wanted and an appropriate inscription. In the case of memorials for cremated remains, an application may not be submitted until a minimum of three months has elapsed between the burial of the person to be commemorated and the application for permission for the memorial, in accordance with Regulation 4.1.4.
- 4.4.4 A parish priest is not bound to give his or her consent to any application although applicants may appeal any such decision by applying to the Chancellor for a faculty (see below).
- 4.4.5 **A parish priest shall not be bound by decisions of previous parish priests made in contravention of these Regulations (or which would not otherwise have been authorised by these Regulations had they been in force at the relevant time). In particular, the existence of memorials/gravestones inappropriately authorised in the past and contrary to these Regulations, shall not be grounds for further introductions of such memorials/gravestones.**
- 4.4.6 **All applications for a faculty for a grave reservation should be accompanied with a marked location on a copy of the current churchyard plan. If the Petition is granted, then the parish's churchyard plan must be marked up with an appropriate reference to the Petition and the location of the reserved grave.**

4.5 Memorials/gravestones and other matters for which a faculty from the Chancellor is required

- 4.5.1 If a parish priest receives an application for a memorial/gravestone which he or she is not authorised to approve under these Regulations, **the parish priest must inform the applicant that he or she is not in a position to grant permission and that the matter can only be authorised by a faculty.** In such cases it will usually have to be demonstrated that there is some substantial reason for permission to be given.
- 4.5.2 The permanent removal of a memorial/gravestone, for which the parish priest has given his or her consent, requires a faculty. The temporary removal for repair or the addition of a further inscription (provided that they comply with Schedule 1) may be authorised by the parish priest provided that no changes are made to any existing names or inscriptions on the memorial/gravestone.
- 4.5.3 The parish priest cannot authorise the removal of a memorial so that wording can be altered because the views of those who have legal title as the heir at law to the memorial have a different view about the person buried than those who ordered the original inscription. Any

such removal and alteration will require a faculty and will have to demonstrate exceptional reasons.

- 4.5.4 The removal of a memorial/gravestone in order to replace it with one for the purposes of recording additional names or inscriptions because there is insufficient space on the original memorial requires a faculty unless:
- (a) the memorial/gravestone to be removed is less than 50 years old and is of no historical interest; and
 - (b) the replacement memorial/gravestone complies with Schedule 1 of these Regulations and may be authorised by a parish priest; and
 - (c) the applicant has confirmed that all interested parties have been consulted on the proposed changes to the memorial/gravestone; and
 - (d) no changes are made to any existing names or inscriptions on the memorial/gravestone¹.

4.6 ***Application procedure for a faculty***

- 4.6.1 Applicants should download a faculty application form from the website of the Diocese of Gloucester or request a form from the churchwarden of the relevant parish. In addition, applicants should also complete sections A, B, C, D and E of the memorial/gravestone application form set out at schedule 2 to these Regulations and submit this along with the completed faculty application.
- 4.6.2 A non-refundable statutory fee (currently £260 + VAT², January 2020) is payable in respect of the application. This fee is subject to periodic review and therefore applicants should check with the DAC as to the correct fee payable before submitting their petition). These fees help in covering the maintenance costs of keeping churchyards in good order.
- 4.6.3 Details of the proposed design must be fully described on the faculty application form (or accompanying memorial/gravestone application form - see Regulation 4.6.1). Applicants should contact the DAC if they require advice on completing the petition/memorial/gravestone application form or the process involved.
- 4.6.4 Once the petition and other supporting documents have been lodged at the Diocesan Registry and the fee paid, a public notice is displayed at the church. Once due notice has been given, the relevant papers will be sent to the Chancellor together with any letters or other communications either in support of or opposing the application. The Chancellor will then make a decision as to whether or not to grant the requested faculty. If the petition is opposed, further fees may be incurred and there may have to be a hearing before the Chancellor. The Chancellor has wide powers to award costs against any of the parties involved in the application.

5 **Burial of cremated remains**

5.1 ***General***

- 5.1.1 (For the rights to have cremated remains interred in a churchyard, see Regulation 2). Cremated remains may normally be interred either in an existing grave or in a part of the churchyard designated for the purpose by faculty. The established practice of interring

¹ All four conditions need to be satisfied in these circumstances.

² No VAT is payable on faculties for grave space reservations.

cremated remains in existing family graves is preferred.

- 5.1.2 Save as provided in Regulation 5.1.1, the interment of cremated remains within an area of the churchyard otherwise designated for the burial of coffins is not permitted.
- 5.1.3 The interment of cremated remains within a family grave in a churchyard closed by Order in Council may require a faculty and the DAC must be consulted before any arrangements are made in order to clarify the position.
- 5.1.4 Cremated remains should either be buried in a small untreated soft wood casket or poured into a hole in the ground. The scattering of cremated remains is not permitted in any Church of England churchyard or burial ground in the diocese.

5.2 **Memorials**

- 5.2.1 For all cremation memorials, the introduction of a new stone requires the permission of the parish priest whose written consent must be obtained before a memorial/gravestone is placed. In accordance with Regulation 4.4.3 (c), the stone should be properly bedded tablets of stone laid flush with the ground of a size not exceeding 18" x 12" x 2" (450mm x 300mm x 50mm) (see diagram in schedule 1 - page 20). The type of stone permitted is the same as for memorials/gravestones. Inscriptions on tablets should include the name of the deceased and dates of birth and death.
- 5.2.2 Additional inscriptions may be made to existing grave memorials provided such additions exactly match the style and appearance of the earlier inscription and are approved by the parish priest.
- 5.2.3 Applications should be made using the form at Schedule 2. The parish priest will not be able to consider an application until it has been confirmed that all interested family members have been consulted and do not object to the proposals.
- 5.2.4 Where a memorial to an individual already exists, a second memorial (whether in the same or another churchyard) to that individual can only be authorised by faculty. This situation may arise where cremated remains are not all interred in the same place.
- 5.2.5 Any proposed memorial outside these Regulations requires faculty permission from the Chancellor.

5.3 **Gardens of Remembrance**

- 5.3.1 The establishment of any newly reserved areas for the disposal of cremated remains (commonly referred to as a Garden of Remembrance), requires the grant of a faculty by the Chancellor. Before any application for a faculty is submitted, advice should be sought from the DAC. In most cases a visit from a DAC delegation will be necessary and the PCC should therefore contact the DAC secretary in the first instance.
- 5.3.2 Such a reserved area should ideally be large enough for the requirements of at least the next 50 years, after which a faculty application can be made for it to be re-used. This fact should be made clear to those intending to make use of the area for cremation interments. For this reason and for the sake of good maintenance, the permanent marking of burial spaces is undesirable.
- 5.3.3 It is imperative that the PCC maintain a proper system of defining and recording separate interment/burial spaces. No interments are permitted within 4 feet (1.25m) of the wall of a church in order to avoid deterioration of the wall due to a build-up of earth and for building

maintenance access.

- 5.3.4 The boundary of the reserved area should be defined on the ground by wooden studs or stone setts, whose surface is level with the ground, and placed at intervals of 300mm unless there is an existing natural or man-made boundary (hedge, wall, path, etc.). A scale plan of the area on which precise locations of interment of cremated remains can be recorded should be kept and maintained in the church.
- 5.3.5 In granting a faculty for a new Garden of Remembrance, or an additional Garden of Remembrance in the same churchyard, or re-use of an existing garden, the Chancellor will normally require a condition that limits commemoration to a Book of Remembrance in the church or central marker stone bearing an appropriate general inscription and the names of those whose cremated remains have been interred in the Garden of Remembrance. This is because:
- (a) for aesthetic and maintenance reasons, permanent marking of burial spaces is undesirable;
 - (b) on an individual basis, commemoration by means of small horizontal tablets may not be considered visually intrusive; however, the cumulative effect of such an approach over a large area can be destructive of the character of the churchyard;
 - (c) extensive areas of paving are essentially urban in character, detract from the visual pleasures of the scene and limit the natural habitat for plant life;
 - (d) the area may require re-use after, say, 50 years and that any tablets will then need to be removed.
- 5.3.6 The preferred approach is one where there are no individual memorials/gravestones "on site" and either a Book of Remembrance is available in the church, in a position affording opportunity for private prayer and contemplation for the bereaved, or an appropriate central marker stone is provided in the Garden of Remembrance which bears an appropriate general inscription describing the purpose of the area. Both require a faculty and the advice of the DAC should be sought before either a book and its display case is purchased for introduction into the church, or a design of the proposed central marker stone is finalised.
- 5.3.7 Any extension of a Garden of Remembrance will require a new faculty.
- 5.3.8 A faculty is required for the re-use of interment spaces within a Garden of Remembrance, unless the original faculty which established it made provision for its perpetual use.

6 Vaults and above-ground funerary edifices

- 6.1 The construction of a brick-lined vault, bricked grave or mausoleum in a churchyard requires the authority of the Chancellor by way of a faculty. A faculty will only be granted in exceptional circumstances.
- 6.2 Where an application is made for the construction of such a vault, the Chancellor will require an assurance that:
- 6.2.1 the DAC structural and archaeological advisers have no objections to the proposed construction;
 - 6.2.2 any memorial to be erected over the vault will, unless authorised by the faculty approving

the construction of the vault, comply with these Regulations;

6.2.3 a fund for future maintenance will be established if the faculty is granted; and

6.2.4 any necessary local government planning consent (if required) has been obtained.

7 Interment within or below the church

Interment within or below the church itself requires a faculty in each case. It is recommended that an initial discussion is held with the parish priest, relevant Archdeacon and the DAC's archaeological adviser before making a formal application.

8 Flowers

8.1 Except where the design of a memorial/gravestone includes an integral vessel for plants or cut flowers, flowers may only be placed in a removable container. Wreaths and cut flowers may be placed in such containers or laid on any grave, but must be removed as soon as they appear to be withered or dead.

8.2 Artificial flowers are not allowed except for Remembrance Day poppies and traditional Christmas wreaths. They should be removed after no more than two months.

8.3 The PCC may, at its discretion, at any time remove and dispose of wreaths, cut flowers or artificial flowers placed in a churchyard if it is considered that, in the PCC's reasonable opinion, they have deteriorated and/or have become unsightly.

8.4 Bulbs and small annual plants may be planted in the soil of any grave (but not in any container). However, no trees or shrubs may be planted without the agreement of the relevant PCC (see Regulation 12.2 below) and the consent of the relevant Archdeacon (to be provided by way of a written notice following consultation with the Archdeacon).

8.5 In accordance with Regulation 1.6, the PCC may make rules for the location and removal of flowers and a copy of such rules shall be made available both to the family of the deceased before any burial or the interment of cremated remains and should generally be available for perusal in the church porch or other suitable position in the churchyard where they may be freely consulted by members of the public.

8.6 A parish priest, churchwarden or whoever is authorised by the PCC to look after the churchyard is permitted to remove unsightly flowers and any items not permitted by these Regulations and any other permitted items if they consider they are not maintained to an acceptable and tidy condition.

8.7 One suitable toy or tribute may be placed on the grave of a child (i.e. a person under 18 years of age) provided that it is removed after a period of six months. No ornaments or additions may be placed on other graves save for flowers or wreaths as provided in this Regulation 7.

9 Reservation of grave spaces

9.1 Grave spaces may be reserved by faculty for the burial of a coffin and the maximum period of reservation permitted by law is 100 years. Grave spaces cannot be reserved solely for cremated remains. However, reserved spaces (for a coffin burial) may be used for the subsequent interment of cremated remains subject to the agreement of all relevant family members. Accordingly, cremated remains may not be interred in a reserved space prior to the coffin burial(s) of those persons who have the benefit of the grave space reservation unless an additional faculty has been obtained prior to such interment. In any such case the Chancellor would need to be satisfied, as a condition of granting such a faculty, that any such proposed interment of cremated remains would not inhibit the subsequent coffin burial(s) for which the space was reserved. If a coffin has already been buried in a grave space (whether it was reserved or otherwise), then cremated remains

(subject to the agreement of all relevant family members) may be buried in the same space and without faculty permission being obtained unless the grave space has been reserved for one or more further coffin burials which have yet to take place. It should be stressed that a person can only secure burial in a particular spot with the benefit of a grave space reservation granted by way of a faculty.

- 9.2 If the churchwardens are not able to certify that there is sufficient space to meet foreseeable need for burial space for the next five years, then the application must be referred to the PCC for consideration before a faculty petition is lodged. In considering whether to grant a faculty, the Chancellor will give due consideration to the PCC's views and, if applicable, to any policy adopted by the PCC in its own churchyard regulations adopted pursuant to Regulation 1.4 but such matters may not be binding on the Chancellor who will always retain a discretion as to whether or not to grant a faculty.
- 9.3 The Chancellor would not ordinarily expect to receive a petition for a grave space reservation from anyone under the age of 60, unless there are exceptional reasons that necessitate careful and sensitive planning for the future, such as an underlying health condition or where a family wish to reserve space for a family grave or a space adjoining an existing family grave.
- 9.4 Applications should be made direct to the Diocesan Registrar together with the applicable fee. There is no requirement for the application to be sent to the DAC. The appropriate form is attached at Schedule 3 and is available on the Diocese's website www.gloucester.anglican.org/parish-life/church-buildings-and-churchyards/faculties and from the Diocesan Registry. An application form can also be obtained from the DAC secretary (see Regulation 16 for contact details).
- 9.5 The area of the churchyard concerned should be properly surveyed and the petition should be accompanied by a plan setting out the precise measurements relating to the position of the grave space to be reserved from at least two fixed points. There should be a north point shown on the plan. The description of the plot in the schedule to the application should contain reference to each measurement shown on the plan. This is necessary to avoid any confusion that might arise in the future.

10 Exhumation

- 10.1 Whenever a deceased person is buried in consecrated ground, it is assumed that the place of burial is intended to be the final resting place of that individual. The same principle applies when the cremated remains of a deceased person are interred in consecrated ground.
- 10.2 The exhumation of human remains (including cremated remains) from consecrated ground for the purpose of reburial in another place is unlawful, unless it has been authorised by faculty. The relatives or personal representatives of a deceased individual will be deemed in the first instance to have chosen the consecrated place of burial as the final resting place and accordingly a faculty for an exhumation will only be granted in wholly exceptional circumstances.
- 10.3 Anyone seeking a faculty authorising the exhumation of the remains of an individual buried in consecrated ground or cremated remains of such a person will therefore have to put forward special grounds in order to obtain a faculty. Mere convenience of visiting a grave or place of burial or the fact that relatives have subsequently moved to a different area are unlikely to justify the grant of a faculty for disturbing the remains.

11 Burial depths

- 11.1 Subject to Regulation 11.2, no body of either an adult or child shall be buried in a grave in such a manner that any part of the coffin is less than three feet below the level of any ground adjoining the

grave.

- 11.2 No body shall be buried in a grave unless the coffin is effectively separated from any coffin interred in the grave on a previous occasion by means of a layer of earth not less than six inches thick.

12 Commonwealth War Graves Commission

- 12.1 No sign informing visitors that a churchyard or other burial ground contains commonwealth war graves may be erected without a faculty.
- 12.2 Applications for a faculty to authorise the erection of a sign under Regulation 12.1 will be considered on a case by case basis. As a general rule, the smaller sign produced by the Commonwealth War Graves Commission (measuring 150mm x 210mm), will normally be preferred over the larger alternative (measuring 230mm x 420mm).
- 12.3 The Commonwealth War Graves Commission has a remit under Royal Charter to ensure that all war casualties are commemorated in perpetuity with a fitting marker. In order for a marker to meet the criteria to be a fitting commemoration, the name of the person commemorated and their date of death must be legible. Any application by the Commonwealth War Graves Commission to install a replacement headstone in accordance with this remit (even if the old memorial is not removed) will require a faculty.

13 American-style caskets

- 13.1 The parish priest may refuse to allow the burial of unusually large coffins. If an applicant is proposing to order one of these, they should consult with their parish priest to see whether it will be permitted in the churchyard.

14 Trees

- 14.1 The upkeep of trees within a churchyard is the responsibility of the PCC. This is the case even where the churchyard has been closed unless responsibility for the maintenance of the churchyard has been passed to the local authority.
- 14.2 A range of works to trees in a churchyard may be undertaken without a faculty in accordance with List A and List B in Schedule 1 to the Faculty Jurisdiction Rules 2015 (as amended). Carrying out works in List A or List B is subject to conditions set out in the list.
- 14.3 "List A" matters may be undertaken by an authorised person without a faculty and without the need for consultation, subject to any conditions specified in the Faculty Jurisdiction Rules 2015.
- 14.4 Paragraph A8 of List A covers the following matters:
- 14.4.1 The felling, lopping or topping of a tree the diameter of any stem of which does not exceed 75 millimetres (measured over the bark at a height of 1.5 metres above ground level).
- 14.4.2 The lopping or topping of any tree:
- (a) that is dying or dead; or
 - (b) has become dangerous
- 14.4.3 The removal of dead branches from a living tree.
- 14.5 "List B" matters may be undertaken by an authorised person without a faculty if the Archdeacon has been consulted on the proposal and has given notice in writing that it may be undertaken without a faculty but subject to any conditions specified in the Faculty Jurisdiction Rules 2015 and/or imposed

by the Archdeacon (who must consult the DAC before deciding whether to give notice of consent).

14.6 Paragraph B7 of List B covers the following matters:

14.6.1 The planting of trees.

14.6.2 The felling of a tree:

- (a) that is dying or dead; or
- (b) has become dangerous.

14.6.3 All other works to trees (whether or not prescribed in List A) except felling.

14.7 The felling of a tree that is neither dead nor dying and which has not become dangerous cannot be carried out under List A or List B and requires a faculty.

14.8 In undertaking any works to trees, regard must be had at all times to guidance issued by the Church Buildings Council under section 51(3) of the Ecclesiastical Jurisdiction and Care of Churches Measure 2018. A copy of the latest guidance can be found here:
www.churchcare.co.uk/images/Guidance_to_parochial_church_councils_on_the_planting_Lists_A_and_B.pdf.

15 **Closure of churchyards**

15.1 In order formally to close a churchyard, a PCC should apply to the Ministry of Justice for an Order in Council using the application form issued by the Ministry of Justice and available on its website.

15.2 In order for the churchyard to be closed, one of the following grounds must be met:

15.2.1 That there is no proper room for new graves.

15.2.2 That further burials would be contrary to decency.

15.2.3 That the discontinuance of burials would prevent or mitigate a nuisance.

15.2.4 That further burials would constitute a health risk.

15.3 The usual reason for wishing to close a churchyard is because there is no proper room for new graves, but this will not be a sufficient reason if the church has already acquired other ground in which burials can still be made.

15.4 If and when an Order in Council closing the churchyard is obtained, a PCC may request the appropriate local authority take over the maintenance of the closed churchyard.

15.5 The Order in Council will not remove the legal effects of consecration and the churchyard will therefore remain subject to the faculty jurisdiction. The churchyard may still be used for the interment of cremated remains provided that (a) this takes place in a Garden of Remembrance provided that it has been approved by faculty or (b) the proposed interment falls within an express exemption for which provision has been made in the applicable Order in Council or (c) it is a one-off interment for which a faculty has been obtained from the Chancellor. However, no further coffin burials are possible unless the Order in Council expressly permits (for example, it may be possible for further burials to take place in specified places such as in existing graves or those reserved by faculty, provided that certain conditions are met). But it should be noted that the Chancellor has no power to alter the terms of an Order in Council and that any person who permits the burial of a body (i.e. a coffin burial) in a closed churchyard that is not expressly permitted under the terms of

the relevant Order in Council commits a criminal offence.

16 Legal reservations

- 16.1 These Regulations shall take effect subject always to any licences, faculties, decrees, orders or regulations, particular or general, which may be made and issued from time to time by the Chancellor of the Diocese.
- 16.2 The Consistory Court does not usually seek to exercise jurisdiction in the straightforward day-to-day management of the churchyard and the consent of the parish priest is, by custom, sufficient authority in such cases permitted under Regulation 4.3 above, provided that the parish priest gives his or her consent in writing.
- 16.3 In all cases not covered by these Regulations, or where there is controversy, upset and potential cost or where, for any reason, the parish priest shall have declined to give his or her consent to any proposal, the applicant shall be required to obtain the authority of a faculty. In order to avoid any controversy, families are encouraged to establish in good time the wishes of their relatives and in particular whether they wish to be buried or cremated and in either case where they would wish to be buried or interred. Clarifying such matters beforehand can spare relatives much expense and emotional upset at a later date.

17 Further advice

- 17.1 Further advice may be obtained from the Archdeacons, the DAC Secretary or the Diocesan Registrar (please see the contact details below).
- 17.2 Faculty petition forms, and forms for permission to introduce a memorial/gravestone into a churchyard or to make changes to an existing memorial/gravestone are available from parish priests, the Archdeacons, the DAC Secretary or the Diocesan Registrar or on the Diocese's website www.gloucester.anglican.org/parish-life/church-buildings-and-churchyards/faculties.
- 17.3 Applications for the reservation of a grave space or exhumation should be made directly to the Diocesan Registrar.
- 17.4 These Regulations supersede and replace the third edition of the Diocese of Gloucester Churchyard Regulations issued in 2015.

18 Useful contacts

Archdeacon of Cheltenham

The Venerable Phil Andrew
Bishop of Gloucester's office, 2 College Green,
Gloucester, GL1 2LY
T: 01452 835594 / 07498 052045
E: archdchelt@glosdioc.org.uk

Archdeacon of Gloucester

The Venerable Hilary Dawson
Bishop of Gloucester's office, 2 College Green,
Gloucester, GL1 2LY
T: 01452 835583 / 07719 310045
E: archdglos@glosdioc.org.uk

The DAC

The Church Buildings Team
Church House, College Green, Gloucester,
GL1 2LY
T: 01452 410022
E: dac@glosdioc.org.uk

Diocesan Registrar

Mr Jos Moule
Veale Wasbrough Vizards
Narrow Quay House, Narrow Quay, Bristol,
BS1 4QA
T: 0117 314 5680
E: gloucesterregistry@vww.co.uk /
faculties@vww.co.uk

Diocesan Records Office

Gloucestershire Archives
Gloucestershire County Council, Clarence Row,
Alvin Street, Gloucester, GL1 3DW
T: 01452 425295
E: archives@gloucestershire.gov.uk

19 **Relevant Publications and Useful Addresses**

The Churchyards Handbook (Church House Publishing 2012)

Available for purchase from Church House Bookshop, 31 Great Smith Street, Westminster, London, SW1P 3BN t: (020 7799 4064) or www.chbookshop.hymnsam.co.uk.

Memorials by Artists (H Fraser, 1998)

Illustrated booklet to assist in identifying suitable artist letter-cutters who can provide individual and characteristic monuments.

Available Harriet Frazer, Snape Priory, Saxmundham, Suffolk, IP17 1SA.

The National Association of Memorial Masons

1 Castle Mews, Rugby, Warwickshire, CV21 2XL t: 01788 542264

e: enquiries@namm.org.uk w: www.namm.org.uk.

The Crafts Council

44a Pentonville Road, London, N1 9BY t: 020 7806 2500

e: reception@craftscouncil.org.uk

w: www.craftscouncil.org.uk.

Schedule I Parish priest's permission

Size

In relation to the burial of any body (but not the interment of cremated remains) a parish priest **may approve** upright grave markers up to the following maximum dimensions (measured from the surface of the ground):

- Height: 4'0" (1200mm) (Inclusive of any plinth height)
- Width: 3'0" (900mm) (Inclusive of any plinth width)
- Depth (thickness of the stone): 6" (150mm) (see illustration below)

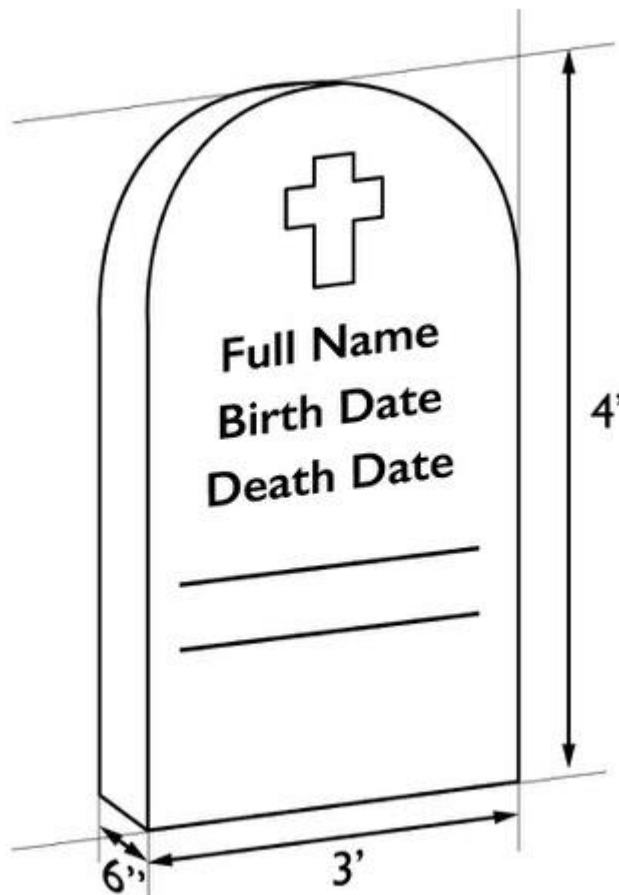

- Any horizontal plinth should project no more than 9" beyond the front face of the upright stone, and no more than 3" behind (see illustration below).

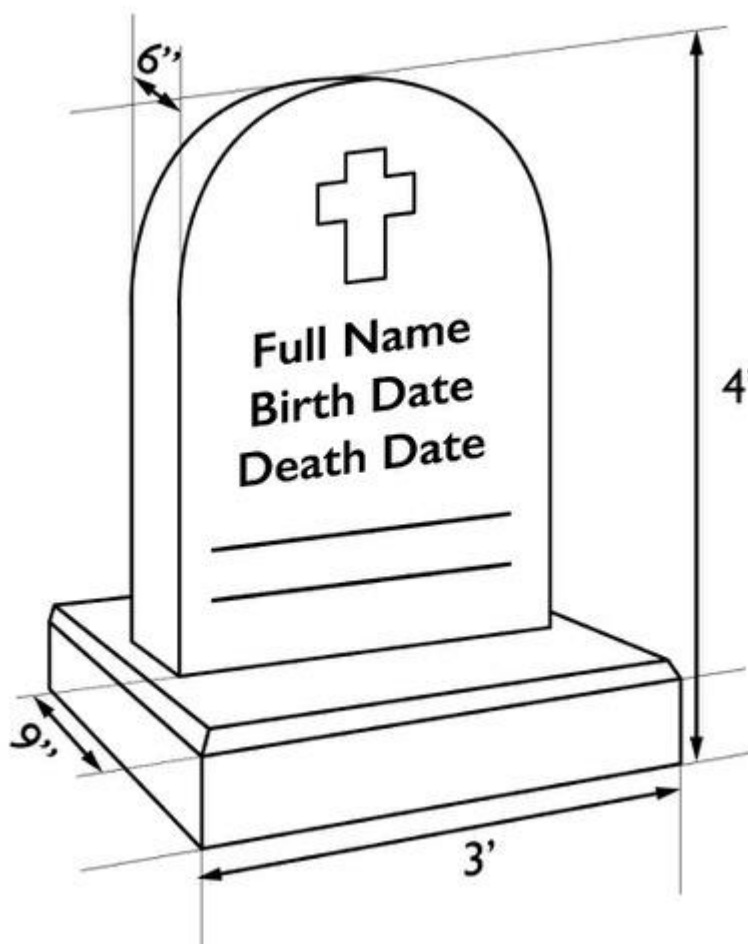

In relation to the burial of any body (but not the interment of cremated remains) a parish priest **may also approve** sloping book markers up to the following dimensions inclusive of any supporting plinth (see illustration below):

Sloping book:

- Length: 2'0" (600mm)
- Width: 2'6" (750mm)
- Height: 6" (150mm) at the highest point (but must slope by not less than 2" (50mm)).

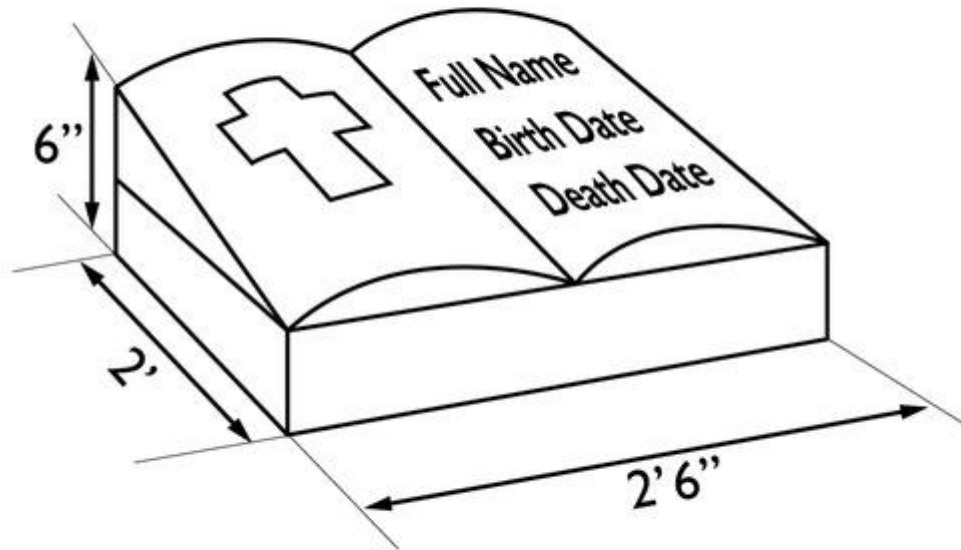

In relation to the interment of cremated remains, a parish priest **may approve** flush fitting horizontal markers up to the following dimensions (see illustration below) :

- Length: 18" (450mm)
- Width: 12" (300mm)
- Depth: 2" (50mm)

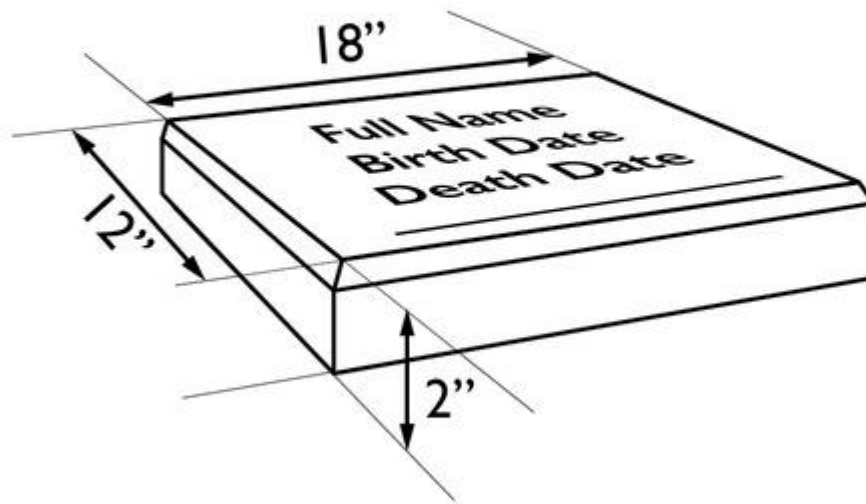

Horizontal markers that exceed these dimensions may only be approved by the parish priest if (a) a majority of the markers already introduced into the churchyard exceed the dimensions referred to above and (b) the PCC has approved the proposal and confirmed that such larger stone qualifies on that basis. In any such case, the dimensions of such larger stone should not exceed the dimensions of the most prevalent marker in such churchyard.

These measurements are **not** intended to define standard proportions of memorials/gravestones, which may be of any dimensions within the limits above.

Shape

A parish priest **may only permit** the forms of memorial/gravestone described at Regulations 4.3.2 and 4.3.3 to above. This means that a parish priest may **not** permit horizontal ledger slabs, crosses (other than wooden crosses), kerbs, chippings or sculptures.

In the case of headstones, the memorial **may be** of the monolith type i.e. fixed

	<p>directly into the ground, or it may have a separate base and plinth (see illustrations above). Headstones may be curved or have square tops and accordingly the headstone diagrams in this schedule are illustrative only.</p>
Lettering	<p>On any memorial/gravestone authorised by a parish priest the lettering may be incised or in relief, and may be infilled with gold, black or grey colour (but not more than one such colour). Lead infilled lettering is permitted, but no other form of applied lettering may be authorised by a parish priest.</p> <p>Care should be taking in selecting the wording to be inscribed on the memorial/gravestone, and it is recommended that advice is sought from the parish priest. The wording must be accurate and not misleading and applicants are asked to provide this confirmation in the application form. An imaginative approach to the epitaph is encouraged, but excessive sentimentality should be avoided. Wording must be consistent with the Christian faith.</p> <p>The monumental mason's name or mark may be inscribed on the side or on the reverse in letters no larger than ½inch (13mm) in height. No other advertisement or trademarks may be inscribed on or fixed to a memorial/gravestone.</p> <p>Epitaphs and additional names of deceased persons whose bodies or cremated remains are subsequently buried in an existing grave may be added to the reverse of the memorial/gravestone but only where there is no space on the front of the memorial/headstone.</p>
Decoration	<p>A parish priest may, but only after consultation with the relevant Archdeacon, permit Christian or other appropriate symbols, for example depictions of items connected with the profession or leisure interest of the person commemorated. However, it is important to maintain an acceptable standard of design of such symbols.</p> <p>A parish priest may not permit photographs or ceramic portraits or any other form of depiction of the person commemorated.</p> <p>No advertisement or trademark may be inscribed on the face of the memorial/gravestone. However, the monumental mason's name may be discreetly inscribed on the side or on the reverse of the memorial/gravestone.</p> <p>No other wording, decoration or mark may appear on the reverse of a memorial/gravestone unless authorised by faculty.</p>
Materials	<p>A parish priest may permit memorials/gravestones made of any natural stone or hardwood, except for the following:</p> <ul style="list-style-type: none"> • White marble. • Any granite other than unpolished light grey. • Any use of a reflective polished surface including any honed stone which has a reflective appearance (although memorials/gravestones honed to a matt finish are permitted). <p>If a parish priest has any doubts over the identity or suitability of any material, the matter should be referred to the Secretary of the DAC.</p>

Schedule 2 Memorial/gravestone application form

Diocese of Gloucester

Application form to replace or add to or amend an inscription on an existing memorial/gravestone or to introduce a memorial/gravestone into a Churchyard

Before completing this application form, you are required to read the Diocese of Gloucester Churchyard Regulations [(fourth edition 2020)] (the "**Regulations**"), which can be found on the Diocese of Gloucester's website <http://gloucester.anglican.org/parish-life/church-buildings-and-churchyards/churchyards/>

If you are using this form to apply for permission to replace an existing memorial/gravestone or erect a new memorial/gravestone, please complete each part of the form.

If you are using this form to add an inscription to or amend an inscription on an existing memorial/gravestone, please complete parts A, D, E and F only.

Permission is sought to replace* / erect* / add an inscription to* / amend an inscription on* a memorial/gravestone

Name of Churchyard

Name of Applicant

Address

.....

.....

Email address

Telephone number

Name of Deceased

Date of burial/interment

Relationship of Applicant to the Deceased

PART A - DETAILS OF THE APPLICANT AND THE DECEASED

I/We apply for consent to replace* / erect* / add an inscription to* / amend an inscription on* a memorial/gravestone in the Churchyard named above and confirm that:

- I/We have read the current edition of the Regulations.
- All the factual statements to be inscribed on the memorial/gravestone are accurate and are not misleading.
- I/We have used all reasonable endeavours to consult with all known family members of the deceased who may reasonably be expected to have an interest in the memorial/gravestone and I/We confirm that no such family member has raised an objection to the proposal.
- Save in the case of the erection of a new memorial/gravestone, I/We confirm that I/We am/are the owner of the memorial/gravestone and understand that I/We am/are responsible for its security and safety.
- Where this application is for the addition of any further inscription or the replacement of an existing memorial/gravestone, that I/we am/are the legal owner/s of the memorial/gravestone³.
- I/We understand that if the memorial/gravestone becomes insecure or otherwise unsafe, the Parochial Church Council may direct that the memorial/gravestone be laid flat in order to avoid the risk of personal injury and damage⁴.

I/We agree at all times to comply with the Regulations and acknowledge the right of the Parochial Church Council to remove all items from the Churchyard that are not permitted by the Regulations.

I/We further understand that any consent may be withdrawn as a result of any failure to comply with the Regulations or as a result of any inaccurate or misleading statement included in this application.

I/We undertake to indemnify and keep indemnified the Incumbent (or Priest-in-Charge) and the Parochial Church Council against all costs, liabilities and expenses which he or she may suffer or incur as a result of any failure to comply with the Regulations or arising from any inaccurate or misleading statement made on this application form.

Applicant's signature
Date

³ The owner of a memorial will be the person who commissioned and paid for it and, upon their death, the heir-at-law of the person or persons commemorated. If you are any doubt as to who is the legal owner, you should discuss the matter with the Incumbent (or Priest-in-Charge).
⁴ It is the owner's responsibility to insure the memorial. The Diocese of Gloucester will not be liable for any loss resulting from acts of vandalism, weathering or from acts of God.

PART B - DETAILS OF MEMORIAL/GRAVESTONE (TO BE COMPLETED BY CRAFTSMAN/MONUMENTAL MASON)

Type of memorial/gravestone

Type of stone, colour and shade

Surface finish

Design / shape

(A scale drawing of the memorial/gravestone (not less than 2.5cm = 25cm) must be provided)

Description of any carving or decoration

PART C - DIMENSIONS OF MEMORIAL/GRAVESTONE (TO BE COMPLETED BY CRAFTSMAN/MONUMENTAL MASON)

Plate (maximum height measured from ground surface)	Maximum width
	Maximum height
	Thickness
Plinth (maximum height above ground surface)	Maximum width
	Depth
Distance between front of plate and front edge of plinth
Foundation <i>(The foundation must not project above ground level and should be covered by soil)</i>	Material
	Dimensions
OR	
Cremated remains tablet	Shape
	Dimensions

PART D - PROPOSED INSCRIPTION

<p>Existing inscription</p> <p><i>(To be completed only where there is an existing memorial/ gravestone)</i></p>	<p>.....</p> <p>.....</p> <p>.....</p> <p>.....</p> <p>.....</p> <p>.....</p>
<p>Proposed inscription</p>	<p>.....</p> <p>.....</p> <p>.....</p> <p>.....</p> <p>.....</p> <p>.....</p>
<p>Any relevant information explaining the reason for the proposed wording</p>	<p>.....</p> <p>.....</p> <p>.....</p> <p>.....</p> <p>.....</p>
<p>Please confirm the type and style of lettering.</p>	<p>.....</p> <p>.....</p>
<p>Is the lettering of the inscription to be painted or gilded?</p> <p>If so, please provide further details.</p>	<p>.....</p> <p>.....</p>

PART E - DETAILS OF CRAFTSMAN/MONUMENTAL MASON

Name

Address

.....

.....

Email address

Telephone number

I/We confirm that:

- I/We have read the Diocese of Gloucester Churchyard Regulations and confirm that in my/our opinion that the proposed memorial/gravestone complies with these Regulations.
- The memorial/gravestone will not be erected until written permission has been obtained from the Incumbent or the Chancellor of the Diocese of Gloucester.
- If approval is given, the design of the memorial/gravestone will not be altered before it is erected.
- I/We will ensure that the grave and its immediate surroundings are left neat and tidy and level following completion of the work.
- Due account has been taken of the nature of the ground and any potential settlement problems and that the proposed method of fixing accords with BS 8415, and I/we agree to indemnify the Incumbent, Churchwardens and the Parochial Church Council against any liability that may arise out of the failure on my/our part to construct and install the memorial/gravestone in accordance with BS 8415.
- I/We acknowledge that if the memorial/gravestone is found to have been inadequately fixed we will be liable at the direction of the Chancellor to meet the cost of its removal and/or refixing.
- I/We acknowledge that if a memorial/gravestone is placed which does not comply with the application submitted and the permission granted, those placing the memorial/gravestone will be liable for the cost of its removal.

Craftsman/Monumental Mason's signature

Date

PART F - INCUMBENT'S (OR PRIEST-IN-CHARGE'S) CONSENT

Name

Position

I believe that the memorial/gravestone (including the inscription) described in this application complies with the Regulations and hereby grant permission for its erection.

The fee for this work will be: £.....

A cheque for this amount should be made payable toPCC.

I do not believe that the memorial/gravestone (including the inscription) described in this application complies with the Diocese of Gloucester Churchyard Regulations and for that reason, I refuse permission for its erection.

For the following reason I am not prepared to grant permission for the erection of this memorial/gravestone.

.....
.....
.....
.....

Incumbent (or Priest-in-Charge) signature **Date:**
.....

Notes for applicants

The size, shape, lettering, decoration and materials permitted by the Diocese of Gloucester are confirmed in the Regulations. If you have any questions in relation to the interpretation of the Regulations and are unsure whether your proposals meet the criteria set by the Diocese of Gloucester, please contact the parish priest in the first instance.

Schedule 3 Grave space reservation form

RESERVATION OF GRAVESPACE IN CHURCHYARD (I)

IN THE CONSISTORY COURT OF THE DIOCESE OF GLOUCESTER

PARISH OF

CHURCH OF

TO THE WORSHIPFUL MARK BERESFORD RUFFELL, Bachelor of Divinity, Barrister-at-Law, Chancellor of the Diocese of Gloucester and Principal of the Consistory Court of that Diocese

The humble Petition of (Names _____) of (Address _____) in the County of (_____) and Diocese of Gloucester

S H O W S :-

That your Petitioner (a Parishioner of the Parish of _____) wishes to have appropriated and reserved to the Petitioner (Names _____)

in _____ Churchyard, _____ Parish of _____ for a piece of ground measuring _____ feet by _____ feet as and for the burial place of the Petitioner which said piece of ground is shown on the plan annexed hereto and thereon edged in red.

That the answers to the questions set out in the document annexed have been duly completed by your Petitioner and are true to the best of his or her knowledge information and belief.

That your Petitioner is prepared to pay the usual interment fees when they become due and any further fees for such headstone or other work as may be permitted.

Your Petitioner therefore humbly prays that a Faculty may be granted authorising the setting apart and appropriating of the said piece of ground when so enclosed as the burial place of your Petitioner exclusive of all others for a period not exceeding one hundred years, to be demarcated by four dropped cornerstones sunk to the level of the grass (or such other demarcation as is agreed).

And your Petitioner will ever pray etc.

Signed _____

Dated _____

I, _____ Incumbent/Priest-in-Charge of the Parish of

_____ consent to the above Petition

Signed _____

Address _____

~~~~~

If no appearance entered in opposition let a Faculty pass the Seal as prayed

**Chancellor**



## RESERVATION OF GRAVESPACE IN CHURCHYARD (2)

### IN THE CONSISTORY COURT OF THE DIOCESE OF GLOUCESTER

#### PARISH OF

#### CHURCH OF

| QUESTIONS                                                                                                                                                                                                                                                       | ANSWERS |
|-----------------------------------------------------------------------------------------------------------------------------------------------------------------------------------------------------------------------------------------------------------------|---------|
| 1. Name, address and occupation of the Petitioner.<br>State whether parishioner or not, and if so, for how long.                                                                                                                                                |         |
| 2. For whom and for how many persons is the space to be reserved?<br>Are they parishioners or with any special claims?                                                                                                                                          |         |
| 3. A plan of the churchyard showing the space proposed to be reserved and giving the measurements should be supplied.                                                                                                                                           |         |
| 4. Are the remains of any other person interred in the space? If so, whose? Date of burial should also be given.<br>Was he or she a parishioner?                                                                                                                |         |
| 5. What is the average number of burials in the churchyard in the past three years?                                                                                                                                                                             |         |
| 6. How long will the churchyard serve for burials at the above average?                                                                                                                                                                                         |         |
| 7. Is it proposed to erect a memorial/gravestone now? If so, this must be authorised separately in accordance with the Churchyard Regulations.<br>NOTE- A faculty for the reservation of a gravespace does not authorise the erection of a memorial/gravestone. |         |
| 8. Does the Parochial Church Council consent to the prayer of the Petition?                                                                                                                                                                                     |         |
| 9. What sum is to be paid as the consideration for the privilege of reserving this space?                                                                                                                                                                       |         |

Signed \_\_\_\_\_

Dated \_\_\_\_\_ 202●